RESEARCH NOTE

APPLICATION OF ANN TECHNIQUE FOR INTERCONNECTED POWER SYSTEM LOAD FREQUENCY CONTROL

H. Shayeghi

*Department of Technical Engineering, University of Mohaghegh Ardabili
Ardabil, Iran, h_shayeghi@aees.org*

H. A. Shayanfar

*Department of Electrical Engineering, IUST
Tehran, Iran, hashayanfar@yahoo.com*

(Received: June 22, 2003 – Accepted: August 11, 2003)

Abstract This paper describes an application of Artificial Neural Networks (ANN) to Load Frequency Control (LFC) of nonlinear power systems. Power systems, such as other industrial processes, have parametric uncertainties that for controller design had to take the uncertainties into account. For this reason, in the design of LFC controller the idea of robust control theories are being used. To improve the stability of nonlinear power system, in the various operating point and under different disturbances this controller has been reconstructed with the use of neural network capability based on Radial Basis Function (RBF). The motivation of using the robust control for training of the RBF neural networks controller is taking the large parametric uncertainties into account in such way that both stability of the overall system and good performance have been achieved for all admissible uncertainties. The simulation results on interconnected power system show that the proposed Nonlinear Neural Controller (NNC) not only is robust to increasing of load perturbations and operating point variations, but also the NNC gives good dynamic response compared with conventional PI and robust controllers. It guarantees the stability of the overall system even in the presence of generation rate constraint (GRC).

Key Words Load Frequency Control, Radial Basis Function Neural Networks, Power Systems, Robust Control

چکیده در این مقاله کاربرد شبکه های عصبی مصنوعی برای طراحی کنترل کننده بار فرکانس سیستمهای قدرت غیر خطی پیشنهاد می گردد. سیستمهای قدرت همانند سایر فرایندهای صنعتی دارای عدم قطعیت پارامتریک بوده که به هنگام طراحی کنترل کننده این عدم قطعیتها باید در نظر گرفته شود. بدین منظور در طراحی کنترل کننده بار فرکانس از ایده تئوریهای کنترل مقاوم استفاده شده و جهت بهبود پایداری سیستم قدرت غیر خطی در نقاط کار گوناگون تحت اغتشاشات مختلف، این کنترل کننده با استفاده از قابلیت شبکه های عصبی مبتنی بر توابع پایه شعاعی بازسازی می گردد. انگیزه استفاده از کنترل مقاوم برای یادگیری کنترل کننده غیر خطی عصبی بزرگتر لحاظ کردن بازه تغییرات عدم قطعیتهای پارامتریک می باشد، به طوری که کنترل کننده ضمن پایداری کل سیستم عملکرد دینامیکی خوبی را در برابر همه عدم قطعیتهای مجاز برآورده نماید. نتایج شبیه سازی بر روی سیستم قدرت بهم پیوسته نشان می دهد که کنترل کننده غیر خطی عصبی (NNC) نه تنها در برابر افزایش اغتشاشات بار و تغییرات نقاط کار مقاوم است بلکه در مقایسه با کنترل کننده های کلاسیک PI و مقاوم از عملکرد دینامیکی خوبی برخوردار است. علاوه بر آن کنترل کننده NNC پیشنهادی پایداری کل سیستم را حتی با وجود محدودیت نرخ تولید تضمین می نماید.

1. INTRODUCTION

In power systems, one of the most important issues is the load frequency control (LFC), which deals

with the problem of how to deliver the demanded power of the desired frequency with minimum transient oscillations [1]. Whenever any suddenly small load perturbations resulted from the demands

of customers occur in any areas of the power system, the changes of tie-line power exchanges and the frequency deviations will occur. Thus, to improve the stability and performance of the power system, generator frequency should be setup under different loading conditions. For this reason, many control approaches have been published for the load frequency control after 1970 decade [2].

An industrial plant, such as a power system, always contains parametric uncertainties. As the operating point of a power system and its parameter changes continuously, a fixed controller may no longer be suitable in all operating conditions. In order to take, the parametric uncertainties into account, several authors have applied the concept of variable structure systems [3,4], various adaptive control techniques [5] to the design of load frequency control. In recent years, fuzzy logic [6], neural networks methods [7,8], robust control [9-11] and improved H_∞ control [1,12] have been applied to the design of LFC.

In this paper, because of the inherent nonlinearity of power system a new nonlinear Artificial Neural Network (ANN) controller that has the advance adaptive control configuration is designed. The proposed controller uses the capability of the ANN based on Radial Basis Function (RBF) for the design of LFC controller. In this work, for the design of nonlinear ANN controller the idea of H_∞ robust controller and applying it to nonlinear power system is being used. The motivation of using the robust control for training of the RBF neural networks controller is to take the large parametric uncertainties into account so that both stability of the overall system and good performance have been achieved for all admissible uncertainties. Moreover, the proposed controller also makes use of a piece of information, which is not used in conventional and H_∞ controllers (an estimate of the electric load perturbation, i.e. an estimate of the change in electric load when such a change occurs on the bus). The load perturbation estimate could be obtained either by a linear estimator, or by a nonlinear neural network estimator in certain situations. It could also be measured directly from the bus. We will show by simulation that when a load estimator is available, the neural network controller can achieve extremely dynamic response. In this study, the Nonlinear Neural Controller

(NNC) is considered for control interconnected power system with two areas with power tie-lines to supply different consumers. The simulation results obtained are shown that the proposed controller not only has good performance in the presence of the generation rate constraint (GRC), but also gives good dynamic response compare to conventional and H_∞ controllers.

2. PLANT MODEL

The power systems are usually large-scale systems with complex nonlinear dynamics. However, for the design of LFC, the linearized model around operating point is sufficient to represent the power system dynamics [1]. Figure 1 shows the block diagram of i-th area power system. Each area including steam turbines contains governor and reheater stage of the steam turbine. According to Figure 1, time-constants of the T_{ri} , T_{ti} and T_{gi} are considered for the reheater, turbine and governor of the thermal unit, respectively. Wherever the actual model consists of the generation rate constraints (GRC) and it would influence the performance of power systems significantly, the GRC is taken into account by adding a limiter to the turbine and also to the integral control part all of areas to prevent excessive control action. The GRC of the thermal unit is considered to be 0.3 p.u. per minute ($\delta = 0.005$). All areas have governors with dead-band effects, which are important for speed control under small disturbances. The governor dead- band is also assumed to be 0.06%. Based on the suitable state variable chosen in Figure 1, the following state-space model will be obtained:

$$\begin{aligned} \dot{\underline{x}} &= \underline{A}\underline{x} + \underline{B}u \\ y &= \underline{C}\underline{x} \end{aligned} \quad (1)$$

Where, \underline{x} is a 12 by 1 state vector, and

$$\underline{u} = [u_1 \quad u_2 \quad \Delta p_{D1} \quad \Delta p_{D2}]^T$$

$$\underline{A} = \begin{bmatrix} A_{11} & A_{12} \\ A_{21} & A_{22} \end{bmatrix}, \underline{B} = \begin{bmatrix} B_1 & 0 & F_1 & 0 \\ 0 & B_2 & 0 & F_2 \end{bmatrix}$$

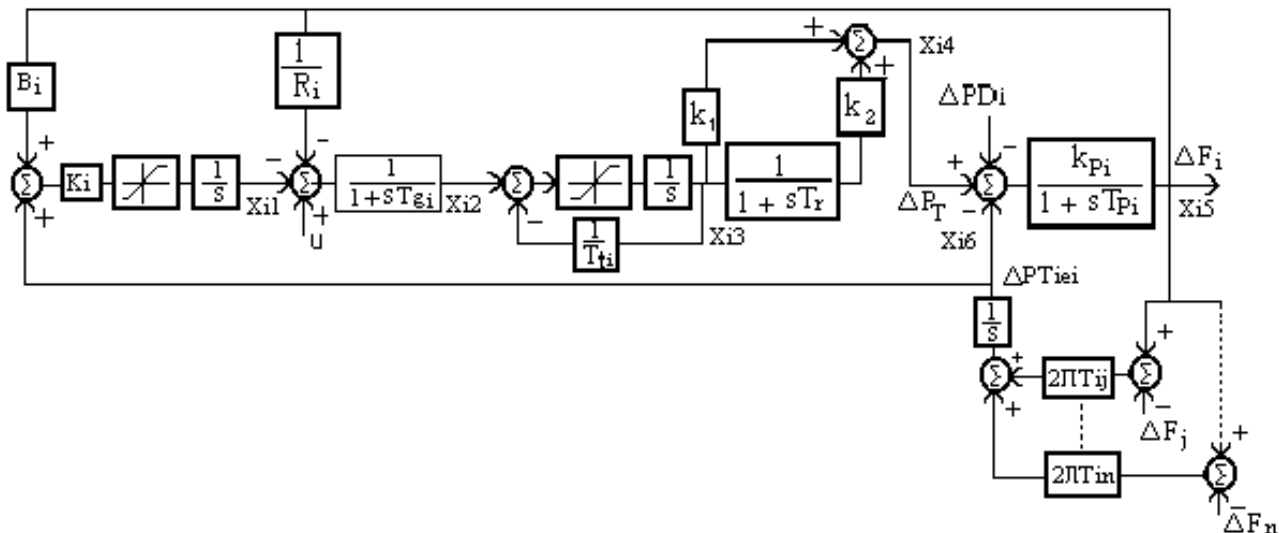

Figure 1. Block-diagram of the *i*th area power system.

TABLE 1. System Uncertainties.

Uncer.	a_i	a_{io}	\bar{a}_i	Δa_i
$\frac{1}{T_{gi}}$	8.33	10.42	12.5	2.07
$\frac{1}{T_{gi} R}$	2.983	4.7	6.51	1.81
$\frac{1}{T_{ti}}$	2.78	3.4735	4.167	0.6935
$\frac{1}{T_{ri}}$	0.0833	0.1042	0.125	0.0208
$\frac{K_p}{T_p}$	4	8	12	4
$\frac{1}{T_{12}}$	0.033	0.0665	0.1	0.0335
T_{12}	0.049	0.0707	0.093	0.0223

$$a_{43} = \frac{k_1+k_2}{T_{ti}} - \frac{k_2}{T_{ri}}, \quad a_{65} = -2\pi \sum_{j \neq i} T_{ij}$$

$$A_{ij} = [a_{zk}], \quad z = k = 1, \dots, 6,$$

$$a_{zk} = \begin{cases} -2\pi T_{zk} & z = 6, k = 5 \\ 0 & \text{otherwise} \end{cases}$$

The submatrices A_{12} & A_{21} are similar. The outputs are defined to be the frequency deviations (ΔF_i) and the deviation of transmission power line (ΔP_{tie}).

As the important characteristics of power systems such as: changing of the generation, loading conditions and system configuration are. Therefore, parameters of the linear model described previously, depend on the operating points. In this paper the range of the parameter variations are obtained by change of simultaneously T_p , T_{12} by 50% and all other parameters by 20% of their typical values which are given below:

$$T_{pi} = 20, K_{pi} = 120, T_{ti} = 0.3, T_{Hi} = T_{gi} = 0.1,$$

$$T_{ri} = 10, R_i = 2.4, K_1 = K_2 = 0.5, T_{12} = 0.0707$$

Denoting the *i*th parameter by a_i , the parameter uncertainty is formulated as:

$$B_i = \left[0 \quad \frac{1}{T_{gi}} \quad 0 \quad 0 \quad 0 \quad 0 \right],$$

$$F_i = \left[0 \quad 0 \quad 0 \quad 0 \quad -\frac{K_{pi}}{T_{pi}} \quad 0 \right]$$

$$A_{ii} = \begin{bmatrix} 0 & 0 & 0 & 0 & K_{1i} B_i & K_{1i} \\ \frac{-1}{T_{gi}} & \frac{-1}{T_{gi}} & 0 & 0 & \frac{-1}{T_{gi} R_i} & 0 \\ 0 & \frac{1}{T_{ti}} & \frac{-1}{T_{ti}} & 0 & 0 & 0 \\ 0 & \frac{K_{1i}}{T_{ti}} & a_{43} & \frac{-1}{T_{ri}} & 0 & 0 \\ 0 & 0 & 0 & \frac{K_{pi}}{T_{pi}} & \frac{-1}{T_{pi}} & -\frac{K_{pi}}{T_{pi}} \\ 0 & 0 & 0 & 0 & a_{65} & 0 \end{bmatrix}$$

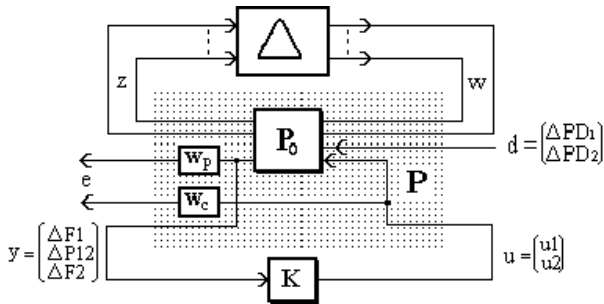

Figure 2. The robust control configuration for the system.

$$a_i = a_{i0} + \delta_i \Delta a_i, \quad |\delta_i| \leq 1, \quad i = 1, 2, \dots$$

$$a_{i0} = \frac{(\underline{a}_i + \bar{a}_i)}{2}, \quad \Delta a_i = \bar{a}_i - a_{i0} \quad (2)$$

Where \bar{a}_i and \underline{a}_i stand for the maximum and minimum value, respectively. Table 1 shows the system uncertainties with their nominal, maximum and minimum values.

3. DESIGN OF H_∞ - ROBUST CONTROLLER

The objective of the controller design in interconnected power system is damping of the frequency and tie-line power deviations oscillations, stability of the overall system for all admissible uncertainties and load disturbances. Thus, frequency and tie line power deviations ($\Delta F_i, \Delta P_{12}$) in two areas power system are considered as controller inputs. The first step in designing of the controller is to separate the parameter uncertainties from the nominal plant. By using 2 equation and following the procedure of reference [1], the state-space model along with uncertainties model will be separated as:

$$P_0 : \begin{cases} \dot{x} = A_0 x + B_1 u + B_2 w \\ Z = C_2 x + C_3 u \\ y = C_1 x \\ w = \Delta z \end{cases} \quad (3)$$

Where the structured uncertainty block is:

$$\Delta = \{\text{diag}(\delta_1 I_2, \dots, \delta_7 I_2, \delta_8); \delta_i \in \mathfrak{R}, \|\Delta\|_\infty \leq 1\}$$

Figure 2 shows the design problem in H_∞ general structure, in which P_0 contains nominal plant and all parametric uncertainties. In order to take modeling error into account, the W_c is considered and W_p also indicates the system performance. The weights have been selected to be as [12]:

$$W_p(s) = \frac{0.33s + 5}{5s + 0.03}, \quad W_c(s) = \frac{0.1s + 1}{s + 1}$$

P in Figure 2 is the generalized plant that should be obtained as H_∞ standard equation [13]. After obtaining the generalized plant of two areas power system, the algorithm described in [14] was used to design the robust LFC controller.

4. NONLINEAR CONTROLLER DESIGN BASED ON ANN

One way of minimizing the frequency oscillation in a single area power system is by using closed-open steam valve method, in which the governor improves the transient stability of the system. The nonlinear controller will produce control signal to the governor. Recently, computational intelligence systems and among them neural networks, which in fact are model free dynamics, has been used widely for approximation functions and mappings. The main feature of neural networks is their ability to learn from samples and generalizing them, and also their ability to adapt themselves to the changes in the environment. In fact, neural networks are very suitable for problems in the real world. They can map from a set of patterns in the input space to a set of desired values in the output space. In other words, neural networks try to emulate the learning activities of the human brain, but in a very simplified fashion. These networks are composed of many simple computational units called neurons, which have fast responses to the inputs. These networks with participation in an especial kind of parallel processing which provide possibility of modeling any kind of nonlinear relations. More accuracy, robustness, generalized capability, parallel processing, learning static and dynamic model of

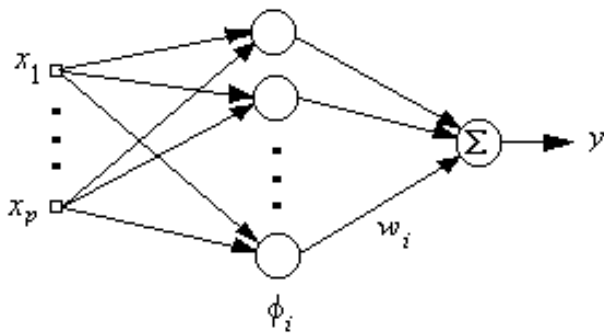

Figure 3. The architecture of radial basis function neural network.

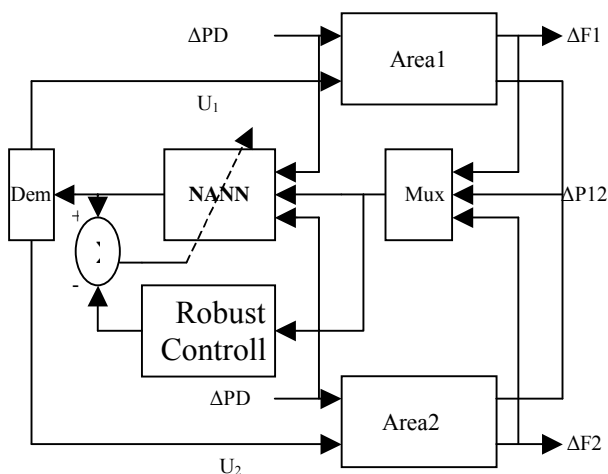

Figure 4. Block diagram of the nonlinear neural network controller.

MIMO systems on collected data and its simple implementation are some of the important characteristics of neural networks that caused wide application of this technique in different branches of sciences and industries, especially in power systems and design of the nonlinear control systems [8,14].

4.1. Radial Basis Function Neural Networks

In the simplest form, a radial basis function network consists of three layers; the input layer, which has source (input) nodes, the hidden layer, which has enough number of neurons, and the output layer, which defines the response of the network with regard to the applied inputs. The mapping from the input layer to the hidden layer is nonlinear, whereas the mapping from the hidden layer to the output

layer is linear. The structure of the RBF network is shown in Figure 3.

In this network, the radial basis functions are Green functions with the following form:

$$\varphi_i(x) = G(\|x - t_i\|) = \exp(-\|x - t_i\|^2), \quad i = 1, \dots, M \quad (4)$$

Where M is the number of neurons in the hidden layer, and can be less than or equal to the number of training samples. The output of this network is an approximation of the desired output and is obtained as follows:

$$F^*(x) = b + \sum_{i=1}^M w_i \varphi_i(x) \quad (5)$$

The weights in the output layer w_i and the center of the Green functions t_i will be obtained during the training of the network [14]. Radial basis function neural networks differ from multilayer perceptron in several respects. RBF networks have a single hidden layer, whereas MLP networks may have one or more hidden layer. In these networks activation function between input layer and hidden layer are nonlinear and between hidden layer and output layer are linear, but in MLP networks activation function each hidden layer with its previous layer was nonlinear and output layer may be linear or nonlinear.

4.2. The Nonlinear ANN Controller Design

Figure 4 shows the block diagram of the closed-loop system, consists of Nonlinear Artificial Neural Network (NANN) controller. The simulation results on a single machine power system show that the performance of RBF controller is much better than multilayer perceptron neural networks controller. Therefore, for the design of the nonlinear LFC controller in two areas power systems the RBF neural networks is being used.

Since the objective of LFC controller design in interconnected power system are damping the frequency and tie-line power deviations with minimizing transient oscillation under the different load conditions. Thus, frequency deviations, tie-line power deviations and the load perturbation are chosen as RBF neural network inputs. Moreover,

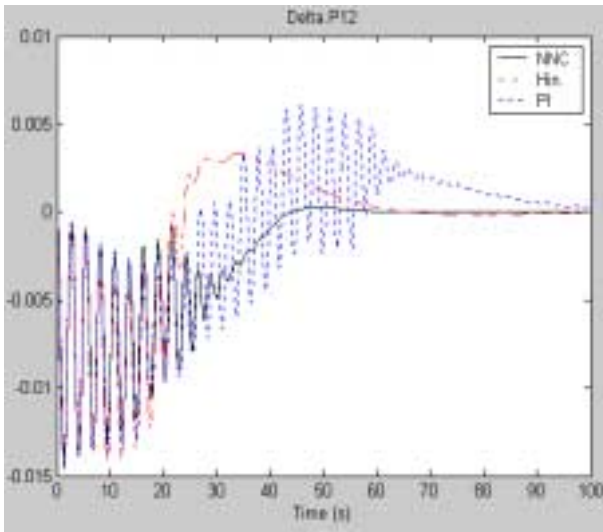

Figure 5. The performance of controllers with nominal parameters.

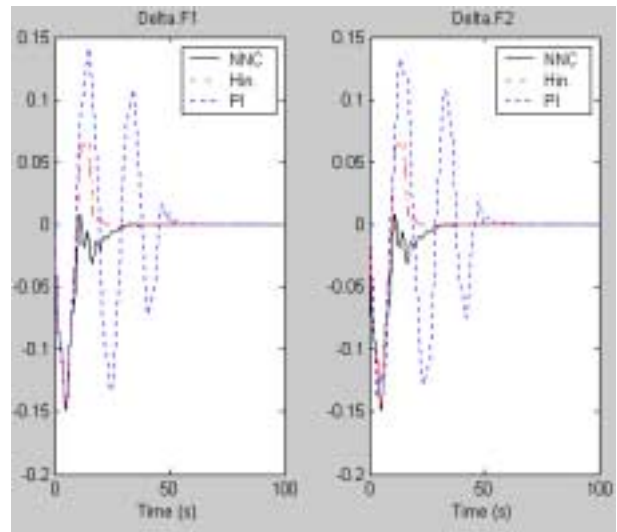

Figure 7. The performance of the controllers for frequency deviations with maximum parameters.

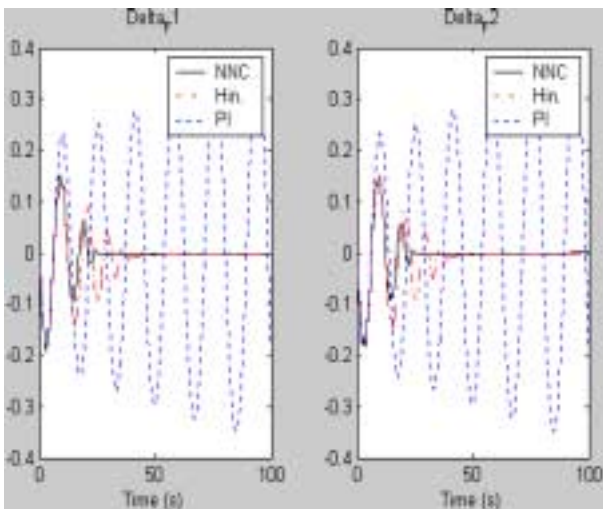

Figure 6. The performance of the controllers for frequency deviations with minimum parameters.

in order to evaluate the control signal (u), the RBF neural network controller makes use of a piece of information which is not used in the conventional and modern controller (an estimate of the load perturbation $\Delta \hat{P}_i$). In general, the load perturbation of the large system is not directly measurable. Therefore, it must be estimated by a linear estimator or by a nonlinear neural network estimator, if the nonlinearities in the system justify it. Such an estimator takes as inputs a series of k samples of

the frequency fluctuations at the output of the generator $[\Delta F(n) \Delta F(n-1) \dots \Delta F(n-k+1)]^T$, and estimates the instantaneous value of the load perturbation based on this input vector. The implementation of such an estimator is beyond the scope of this paper. Here, we assume that the load estimate $\Delta \hat{P}_i$ is available, i.e. $\Delta \hat{P}(n) = \Delta PD(n)$. Thus, frequency deviations, tie-line power deviations and the load perturbation are chosen as the RBF neural network inputs. The outputs of the neural network are the control signals, which are applied to the governors. The data required for the RBF neural network training is obtained from the H_∞ robust controller design in different operating conditions and under various load disturbances.

5. SIMULATION RESULTS

For small sampling time, it can be shown that the discrete-time model is almost the same as the continuous-time model. Hence, the simulations have been carried out in MATLAB using continuous-time domain functions. In this study, the application of RBF neural controller for LFC in two areas power system is investigated. The performance of the NANN controller is compared with the H_∞ controller and PI controller, which has been widely

used in power system.

Figures 5 to 7 depict performances of the NANN, H_{∞} and PI controllers when different load step disturbances in two areas are applied to the system. Figure 5 shows the tie-line power deviations when a 2% and 0.5% load step disturbances are applied in areas 1 and 2, respectively. Figure 6 shows the performances of controllers with applying a 0.5% and 1.5% load step disturbances to 1 and 2 areas, respectively, whereas the parameters are decreased from their nominal values to the minimum values. Figure 7 shows the responses of the controllers when the parameters are increased from their nominal values to their maximum values and a 2% and 0.8% load step disturbance are applied to 1 and 2 areas, respectively. To show the performance of the proposed controller, we run several tests, not shown here.

The simulation results obtained show that the proposed RBF neural network controller is very effective and not only has good performance, even in the presence of the GRC, but also ensures the stability of the overall system, especially when the parameters and the operating conditions of the system are changed. From these figure, it is seen that the NANN controller is superior compared to other controllers against to increasing of the step load disturbances in the areas of power systems, especially when the system parameters are changing.

6. CONCLUSION

This study shows an application of the ANN to automatic generation control in the power system. In this paper, a new RBF neural network load frequency control has been proposed to improve the performance and stability of the power system. This control strategy was chosen because the power systems involve many parametric uncertainties with varying operating conditions. In this work, transient behavior of the frequency of each area and tie line power deviations in the power system with two areas is considered under any load perturbations in any area. The simulation results obtained show that the advantages of the proposed controller are:

1. The proposed controller is effective and

can ensure that the overall system will be stable for all admissible uncertainties and load disturbances.

2. The ANN controller can achieve good performance even in the presence of GRC, especially when the system parameters are changing.

The performance of the proposed controller is better than H_{∞} and PI controllers to the load disturbances at any area in the interconnected power system.

7. REFERENCES

1. Karrari, M., Shayeghi, H., et al., "Design of H_{∞} Controller Load Frequency Control in Electric Power Systems", *Amirkabir Journal of Science and Technology*, Vol. 11, No. 41, (1999), 79-88.
2. Glover, J. D. and Schweppe, F. C., "Advance Load Frequency Control", *IEEE Trans. on PAS*, Vol. 91, (1972), 2085-2103.
3. Jafari-Harandi, M. and Bathee, S. M. T., "Decentralized Variable-Structure and Fuzzy Logic Load Frequency Control of Multi-Area Power Systems", *Fuzzy Logic Symposium*, Malaysia, (1997), 472-475.
4. Bengiamin, N. N. and Chan, W. C., "Variable Structure Control of Electric Power Generation", *IEEE Trans. on PAS*, Vol. 101, (1982), 376-380.
5. Pan, C. T. and Liaw, C. M., "An Adaptive Controller for Power System Load-Frequency Control", *IEEE Trans. on Power Systems*, Vol. 4, No. 1, (1988), 122-128.
6. Sharyati-yazdi, R., Abedi, M. and Menhaj, M. B., "Multi Area Load-Frequency Control Using Fuzzy Logic", *ISRF-IEE: Fuzzy System Symposium*, (1996), 129-134.
7. Beaufays, F., et al., "Application of Neural Networks to Load Frequency Control in Power System", *Neural Networks*, Vol. 7, No. 1, (1994), 183-194.
8. Demiroren, A., et al., "Application of ANN Technique to Load Frequency Control for Three-Area Power System", *IEEE Porto Power Tech. Conf.*, Portugal, Vol. 2, (2001), 523-527.
9. Zhou, R., Wang, Y. and Wen, C., "Robust Load-Frequency Controller Design for Power System", *IEE Proc.*, Vol. 140, (1993), 11-16.
10. Wang, Y., Zhou, R. and Wen, C., "A New Robust Adaptive Load-Frequency Controller with System Parametric Uncertainties", *IEE Proc. of Gen., Tran. and Dis.*, Vol. 141, No. 3, (1994), 184-190.
11. Shayeghi, H., Shayanfar, H. A., "μ Controller Design for Interconnected Power Systems Load Frequency Control", *Proc. of the Inter. Conf. on PES*, No. 352-158, California, USA, May 13-15, (2002), 751-758.
12. Shayeghi, H., Karrari, M. and Menhaj, M. B., "The H_{∞} Theory for Interconnected Power Systems Load

- Frequency Control”, *Eighteenth International Conf. Modeling, Identification and Control*, Innsbruck, Austria, (1999), 199-203.
13. Doyle, J. C., Glover, K., Khargonekar, P. P. and Francis, B. A., “State-Space Solutions to Standard H_2 and H_∞ Control Problems”, *IEEE Trans. control*, Vol. 34, No. 8, (1989), 831-847.
14. S., “Neural Networks – A Comprehensive Foundation”, New Jersey, Prentice Hall, USA, (1994).